

Product Brief

High Tx Output Power 400G ZR+ QSFP-DD DCO Transceiver FTCD3323R1PCL

PRODUCT FEATURES

- Digital Coherent Optics module, QSFP-DD form factor, Type 2A
- IEEE 400GE or n×100GE (n = 1...4) Ethernet compliant host interface
- Coherent 400G/300G/200G/100G optical interface based on OpenZR+ MSA
- High Tx output power (0dBm) and Tx OSNR for compatibility with deployed ROADMs line systems
- Transmission reach > 600km at 400G, with extended reaches at lower data rates
- Full C-band tunable with flexible grid support
- Case temperature range 0°C to 70°C

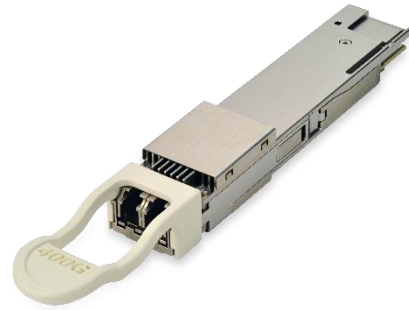

APPLICATIONS

- Metro / regional ROADM networks
- Data center interconnect

The Coherent FTCD3323R1PCL QSFP-DD Digital Coherent Optics (DCO) transceiver supports multi-rate coherent transmission for metro / regional and data center interconnect applications. On the host side, the module can accommodate either a single IEEE 400GE Ethernet signal or multiple 100GE Ethernet signals (n = 1...4) [1] that are multiplexed onto a single line interface. On the line side the module supports 400G, 300G, or 200G line interfaces with 60GBd dual-polarization 16QAM, 8QAM, or QPSK modulation, respectively, as well as a 100G line interface with 30GBd dual-polarization QPSK modulation, as specified by the OpenZR+ MSA [2].

Extending the capabilities of a basic OpenZR+ transceiver, the FTCD3323R1PCL offers up to 10dB higher Tx output power as well as improved Rx sensitivity, providing compatibility with deployed and emerging ROADM line systems.

The transceiver modules are compliant to the QSFP-DD MSA Hardware Specification [4], the Common Management Interface Specification (CMIS) [5] with extensions specified in the OIF Coherent CMIS implementation agreement [6].

PRODUCT SELECTION

Product	Description
FTCD3323R1PCL	400G QSFP-DD Digital Coherent Optics Transceiver, ZR+, High Tx output power, C-band tunable, Pull tab, 0°C to 70°C, LC receptacle

Optical Characteristics

Parameter	Conditions	Symbol	Min	Typ	Max	Unit	Notes
General							
Symbol rate		R_{baud}	30.07		60.14	GBd	
Modulation format			16QAM, 8QAM, QPSK				
Channel frequency range		ν_C	191.300		196.100	THz	
Channel spacing	Flexible grid	$\Delta\nu_C$	6.25	100		GHz	
Frequency accuracy		$\delta\nu_C$	-1.5		1.5	GHz	
Transmitter							
Tx output power configurable range		$P_{\text{Tx,out}}$	-6	0	1	dBm	1
Tx output power tolerance		$\delta P_{\text{Tx,out}}$	-1.0		1.0	dB	2
Tx in-band optical signal to noise ratio	Under modulation, $ \Delta f < 150$ GHz	OSNR_{in}		48		dB/0.1nm	
Tx out-of-band optical signal to noise ratio	Under modulation, $ \Delta f > 150$ GHz, excluding side mode peaks	OSNR_{out}		48		dB/0.1nm	
Receiver							
Rx total input power		$P_{\text{Rx,tot}}$	-30		13	dBm	
Rx signal input power (amplified)	Full Rx OSNR tolerance	$P_{\text{Rx,sig}}$	-12		0	dBm	
Rx OSNR tolerance		ZR400-OFEC-16QAM		22.0		dB/0.1nm	
		ZR300-OFEC-8QAM		19.0			
		ZR200-OFEC-QPSK		14.3			
		ZR100-OFEC-QPSK		11.4			
		400ZR		24.0			
CD tolerance	OSNR penalty < 0.5dB	ZR400-OFEC-16QAM		12.0		ns/nm	
		ZR300-OFEC-8QAM		18.0			
		ZR200-OFEC-QPSK		24.0			
		ZR100-OFEC-QPSK		48.0			
		400ZR	-2.4	2.4			
Rx signal input power (unamplified)	OSNR > 35dB/0.1nm	ZR400-OFEC-16QAM	-23		0	dBm	
		ZR300-OFEC-8QAM	-26		0		
		ZR200-OFEC-QPSK	-30		0		
		ZR100-OFEC-QPSK	-32		0		
		400ZR	-20		0		

Notes:

1. Range of target Tx output power values for which other Tx specifications can be maintained.
2. Deviation from target value under closed loop control, over all operating conditions and life.

Digital Diagnostics Functions

The FTCD3323R1PCL QSFP-DD-DCO module supports the diagnostics interface specified in the Common Management Interface Specification (CMIS) [5] with extensions specified in the OIF Coherent CMIS implementation agreement [6].

Mechanical Specifications

Dimensions of the FTCD3323R1PCL QSFP-DD-DCO module are shown in Figure 1.

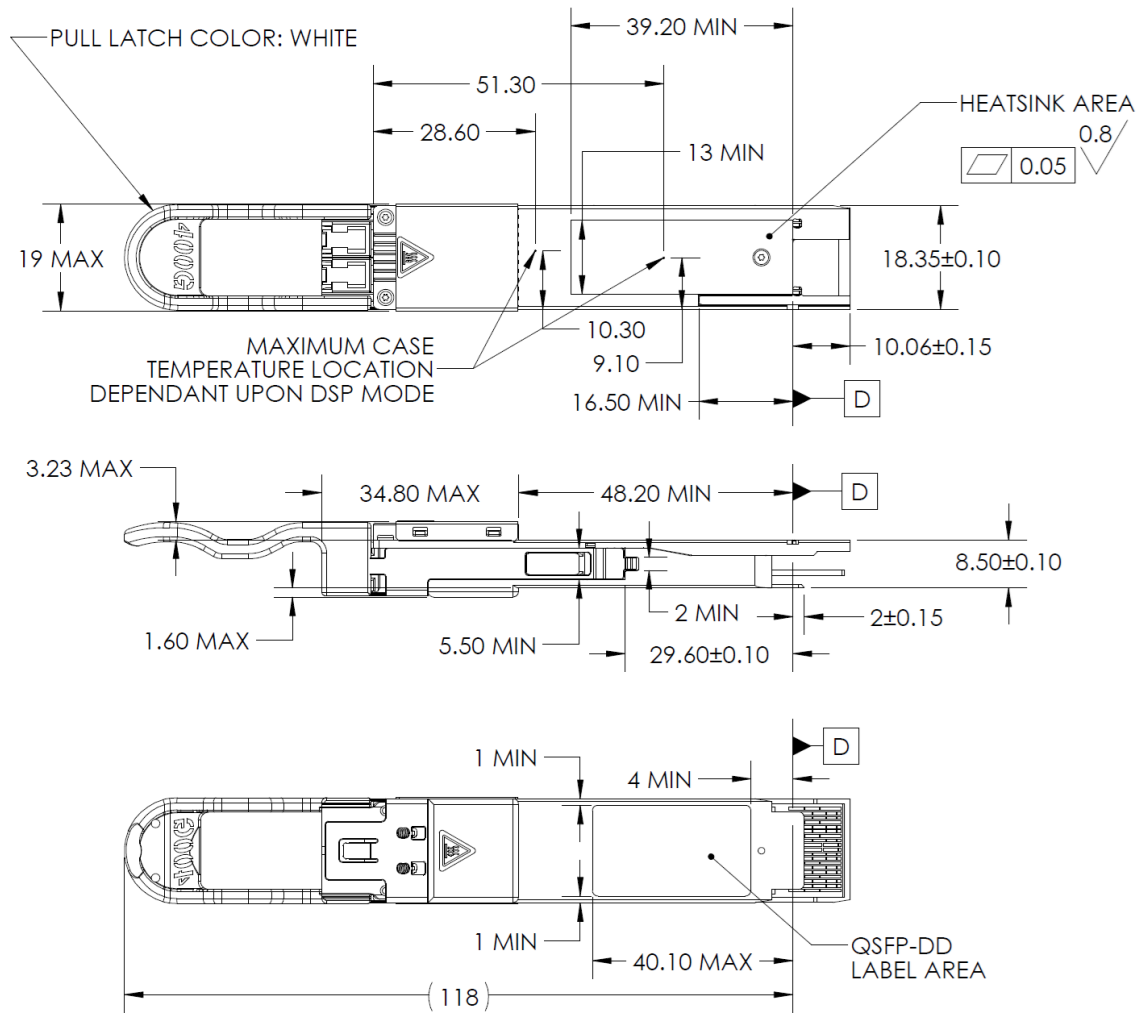

Figure 1 FTCD3323R1PCL QSFP-DD-DCO mechanical outline

Regulatory Compliance

Coherent FTCD3323R1PCL QSFP-DD-DCO transceivers are Class 1 laser products. They are certified per the following standards:

Feature	Agency	Standard
Laser Eye Safety	FDA/CDRH	CDRH 21 CFR 1040.10 and Laser Notice 56
Laser Eye Safety	UL	IEC/EN 60825-1:2014 IEC/EN 60825-2:2004+A1+A2
Electrical Safety	UL	IEC/UL/EN 62368-1:2014

Copies of the referenced certificates are available at Coherent Corp. upon request.

Caution: Use of controls or adjustments or performance of procedures other than those specified herein may result in hazardous radiation exposure.

References

1. IEEE Computer Society "IEEE Standard for Ethernet", IEEE Std. 802.3™-2022.
2. OpenZR+ MSA "Technical Specification", Revision 1.0 (September 4, 2020).
3. OIF "Implementation Agreement 400ZR", OIF-400ZR-01.0 (March 10, 2020).
4. QSFP-DD MSA "QSFP-DD/QSFP-DD800/QSFP112 Hardware Specification for QSFP Double Density 8× and QSFP 4× Pluggable Transceivers" Revision 6.01 (May 28, 2021).
5. QSFP-DD, OSFP, and COBO Advisory Group "Common Management Interface Specification" Revision 5.1 (November 2, 2021).
6. OIF "Implementation Agreement for Coherent CMIS", OIF-C-CMIS-01.2 (March 21, 2022).
7. SNIA "Specification for SFF Module Management Reference Code Tables", SFF-8024 Rev 4.9 (May 24, 2021).

Mouser Electronics

Authorized Distributor

Click to View Pricing, Inventory, Delivery & Lifecycle Information:

[Coherent:](#)

[FTCD3323R1PCL](#)